

**IMPORTANT!** Please read this installation guide thoroughly before installing the 1700G. Use only a high quality digital multi-meter for testing. This product connects to the vehicle's low voltage signal wire and improper installation or testing can result in damage to the vehicle. Never use a test light or logic probe to test wires in this vehicle!

The 1700G interfaces with specific GM vehicles. It converts the signals from the keyless entry, alarm, or remote start into signals that can be understood by the vehicles factory Data Bus system. This allows for interfacing with various factory options such as factory alarms. The 1700G also interfaces with Passlock II and PassKey III systems.

NOTE: The trunk release feature is not available on all platforms.

1700G is a Convenience + Remote Start Bypass Module for more than 50 GM cars. It supports PK2 and PK3 bypass.

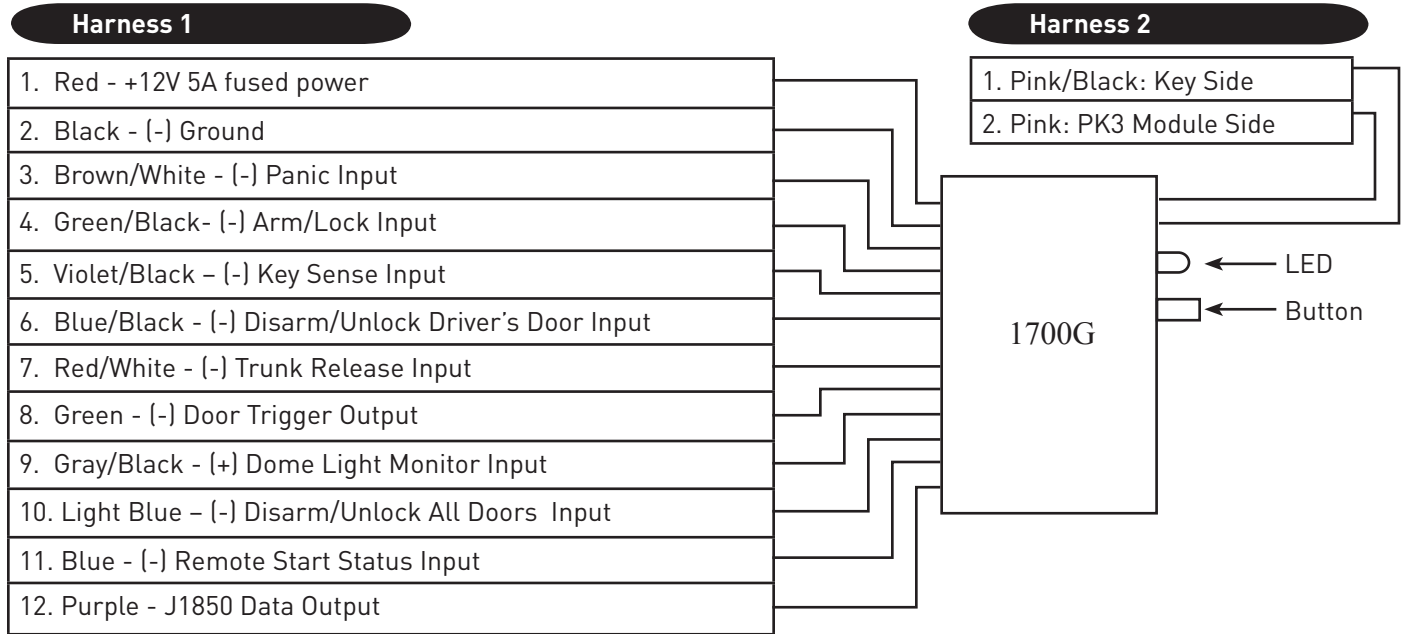

HARNES 1	<b>Note:</b> Wire the Harness. Do not connect the 1700G module until you make all the connections	
Pin #	Color	Details
1	Red	This is +12V 5A fused Input Power. Connect this wire to a constant 12V power source located at the ignition or Battery terminal.
2	Black	Remove any paint form the connection area and connect this wire to the bare metal, preferably in the Driver's kick panel. Do not use the steering column or underdash bracing.
3	Brown/White	Connect this wire to the Auxiliary Channel output from the alarm system to use the vehicle's factory panic alarm.
4	Green/Black	Connect this wire to the negative Lock wire from the after market alarm system.
5	Violet/Black	Connect this wire to the Key Sense Input of the vehicle.
6	Blue/Black	Connect this wire to the Unlock wire of the Aftermarket Alarm System to unlock driver's door.
7	Red/White	Connect this wire to the Auxiliary Channel output from the alarm system to open the trunk
8	Green	Connect this wire to the negative door trigger input for aftermarket alarm system. In Directed systems this wire is Green.
9	Gray/Black	Connect this wire to the positive Domelight circuit in the car.
10	Light Blue	Connect this wire to the Unlock wire of the Aftermarket Alarm System to unlock all doors.
11	Blue	Connect this wire to a wire that goes to ground and stays at ground the whole time the Vehicle is in Remote Start Mode.
12	Purple	Connect this wire to the purple wire in the OBD2 connector located in the pin #2

## HARNESS 2

**Note:** Harness 2 is only required on PK3 vehicles when the security light on the dash illuminates after remote start.

- |   |            |   |
|---|------------|---|
| 1 | Pink/Black | When "ignition power wire" going to the PK3 module is cut, connect this wire to the Ignition switched side of the Ignition wire at the Passkey module (see wiring diagram). |
| 2 | Pink       | Connect this wire to the PK3 module side of the ignition wire at the Passkey Module   |

### Programming:

1. Connect the 12 Pin-Harness to the 1700G module. This powers up the module. If a platform is previously programmed in the unit, the LED will blink to indicate the platform number. If no platform is programmed in the unit, the LED will blink continuously.

2. Press and hold the Programming Button until the Red Led turns OFF.

3. Press the Programming Switch equal to the Platform number to be programmed.  
**Note:** If no action is taken for more than 5 seconds, the module will exit the program routine.

4. Turn ON the Ignition and Start the car. The LED will blink 3 times to indicate that the programming is complete.

If PK3 Vehicle Turns ON Security Light:  
Connect the 2-pin Harness in the following configuration:

- |   |  |
|---|--|
| 1 | Cut the ignition wire going to the PK3 module.                         |
| 2 | Connect the Key cylinder side of this ignition wire to Pink/Black wire |
| 3 | Connect the PK3 side of the wire to Pink wire                          |

#### LEGEND:

- = Bypass only
- X = Bypass + Convenience

See Directechs for most current application

### List of Cars Supported by 1700G Module:

	98	99	00	01	02	03	04	05	06
<b>PLATFORM 1</b>									
Avalanche					•	X	X	X	X
C/K pickup		•	•	•	•	X	X	X	X
Escalade		•	•	•	•	X	X	X	X
Hummer (H2)						X	X	X	X
Sierra		•	•	•	•	X	X	X	X
Silverado		•	•	•	•	X	X	X	X
Suburban		•	•	•	•	X	X	X	X
Tahoe		•	•	•	•	X	X	X	X
Yukon		•	•	•	•	X	X	X	X
<b>PLATFORM 2</b>									
Ascender						X	X	X	X
Bravada		•	•	•	X	X	X		
Envoy		•	•	•	X	X	X	X	X
Rainier							X	X	X
TrailBlazer					X	X	X	X	X
<b>PLATFORM 3</b>									
Aztek			•	•	•	•	•	•	
Grand Prix								X	X
Montana			•	•	•	•	•		
Rendezvous			•	•	•	•	•	•	•
Relay								X	X
Silhouette		•	•	•	•	•	•		
Terraza								X	X
Uplander								X	X
Venture			•	•	•	•			
<b>PLATFORM 4</b>									
Aurora				X	X	X			
Bonneville			X	X	X	X	X	X	
CTS						X	X	X	
Deville				X	X	X	X		
LeSabre			X	X	X	X	X	X	
Monte Carlo			•	•	•	•	•	•	
Seville				X	X	X	X	X	
SRX							X	X	X
<b>PLATFORM 5</b>									
Alero			•	•	•	•	•		
Astro	•	•	•	•	•	•	•	•	
Blazer	•	•	•	•	•	•	•	•	
Cavelier			•	•	•	•	•	•	
Express Van	•	•	•	•	•	•	•	•	•
Grand Am		•	•	•	•	•	•	•	
Impala			•	•	•	•	•	•	
Intrigue			•	•	•	•			
Malibu	•	•	•	•	•	•			
S-10	•	•	•	•	•	•	•		
Safari	•	•	•	•	•	•	•	•	
Saturn S Series			•	•	•				
Savanna	•	•	•	•	•	•	•	•	•
Sonoma	•	•	•	•	•	•	•	•	
Sunfire			•	•	•	•	•	•	

## ignition harness

The Ignition Harness is to be wired only for the Cadillac models listed below, or if the Security Light illuminates after remote start.

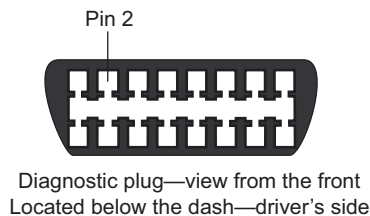
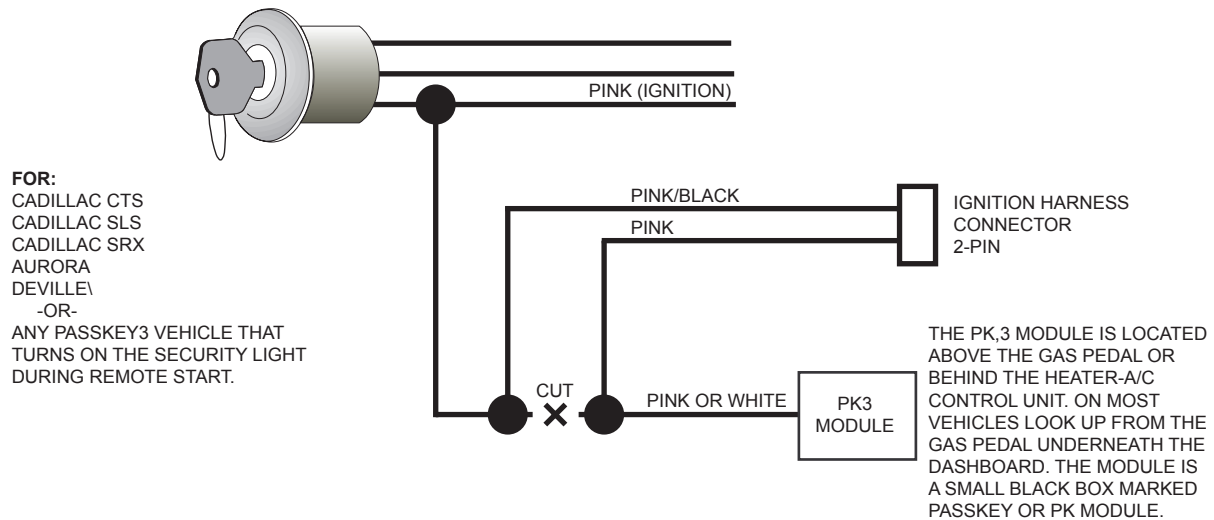

### LIMITED ONE-YEAR CONSUMER WARRANTY

For a period of ONE YEAR from the date of purchase of a Directed Electronics remote start or security accessory product, Directed Electronics. (hereinafter "DIRECTED") promises to the original purchaser, to repair or replace (at DIRECTED's election) with a comparable reconditioned piece, the security or remote start accessory piece (hereinafter the "Part"), which proves to be defective in workmanship or material under normal use, provided the following conditions are met: the Part was purchased from an authorized DIRECTED dealer in the United States; and the Part is returned to DIRECTED, postage prepaid, along with a clear, legible copy of the receipt or bill of sale bearing the following information: consumer's name, address, telephone number, the authorized licensed dealer's name, date of purchase and complete product and Part description.

This warranty is non-transferable and is automatically void if the Part has been modified or used in a manner contrary to its intended purpose or if the Part has been damaged by accident, abuse, unreasonable use, neglect, water, theft, improper service, installation or other causes not arising out of defect in materials or construction. This warranty is automatically void if any Part has had the serial number defaced, altered, or removed. This warranty is automatically void if the Part has had Repair Service performed by anyone other than the Directed Repair Department. This warranty does not cover damage to any Part caused by installation or removal of the Part or any system related thereto. This warranty does not cover labor costs for the removal or reinstallation of the Part.

TO THE MAXIMUM EXTENT ALLOWED BY LAW, ALL WARRANTIES, INCLUDING BUT NOT LIMITED TO EXPRESS WARRANTY, IMPLIED WARRANTY, WARRANTY OF MERCHANTABILITY, FITNESS FOR PARTICULAR PURPOSE AND WARRANTY OF NON-INFRINGEMENT OF INTELLECTUAL PROPERTY, ARE EXPRESSLY EXCLUDED TO THE MAXIMUM EXTENT PERMITTED BY LAW; AND DIRECTED NEITHER ASSUMES NOR AUTHORIZES ANY PERSON OR ENTITY TO ASSUME FOR IT ANY DUTY, OBLIGATION OR LIABILITY IN CONNECTION WITH ITS PRODUCTS. DIRECTED HEREBY DISCLAIMS AND HAS ABSOLUTELY NO LIABILITY FOR ANY AND ALL ACTS OF THIRD PARTIES INCLUDING DEALERS OR INSTALLERS. IN THE EVENT OF A CLAIM OR A DISPUTE INVOLVING DIRECTED OR ITS SUBSIDIARY, THE PROPER VENUE SHALL BE SAN DIEGO COUNTY IN THE STATE OF CALIFORNIA. CALIFORNIA STATE LAWS AND APPLICABLE FEDERAL LAWS SHALL APPLY AND GOVERN THE DISPUTE. THE MAXIMUM RECOVERY UNDER ANY CLAIM AGAINST DIRECTED SHALL BE STRICTLY LIMITED TO THE AUTHORIZED DIRECTED DEALER'S PURCHASE PRICE OF THE PART. DIRECTED SHALL NOT BE RESPONSIBLE FOR ANY DAMAGES WHATSOEVER, INCLUDING BUT NOT LIMITED TO, ANY CONSEQUENTIAL DAMAGES, INCIDENTAL DAMAGES, DAMAGES FOR THE LOSS OF TIME, LOSS OF EARNINGS, COMMERCIAL LOSS, LOSS OF ECONOMIC OPPORTUNITY AND THE LIKE.

Some states do not allow limitations on how long an implied warranty will last or the exclusion or limitation of incidental or consequential damages. This warranty gives you specific legal rights and you may also have other rights that vary from State to State. DIRECTED does not and has not authorized any person or entity to create for it any other obligation, promise, duty or obligation in connection with this Part.